

**TOSHIBA**

## Uninterruptible Power Systems



**3** Year  
Warranty

**IGBT**

**IGBT  
DESIGN**  
94%  
Efficiency

## G8000MM Series

100 to 750 KVA UPS

# G8000MM Main Features

## State-of-the-Art Modular Design Provides Maximum Flexibility



150 KVA G8000MM

The Toshiba G8000MM uninterruptible power system utilizes state-of-the-art design and construction to deliver industry-leading reliability and the flexibility to meet today's critical power demands.

- Technologically Advanced Control of Fast-Switching IGBTs Delivers 94% Efficiency
- Combination Diode Bridge & Broad Range Harmonic Input Filter Delivers Low Input Total Harmonic Distortion (THD)
- Low THD Reduces Heat Loss in Associated Feed Equipment & Increases Component Life
- Self-Contained Modular Design Allows Low Cost Future Expansion
- Combine Up to Eight Modules for Increased Capacity or Redundancy
- Highly Efficient Hybrid Static-Transfer Switch Built Into Each Module
- Parallel Output Tie Cabinet Requires Minimal Intelligence Circuitry Reducing Purchase Cost
- Superior Output Voltage Regulation Provides Non-Distorted Output Power with Minimal Use of Batteries when Subjected to Severe Step Loads
- Generator-Friendly Interface Allows 1.1 KW Generator Capacity to 1.0 KVA UPS Load
- Advanced Battery-Control Ingenuity Produces Low DC Ripple -- Extending Battery & Capacitor Life
- Fail-Safe Design Incorporates Robust, Conservatively Engineered Devices to Reduce Failures & Ensure Reliability

## High Efficiency Design

- G8000MM Efficiency Greater than 90% at Loads 25% & Larger
- Higher Efficiency Means Lower Power Losses Equating to Lower Utility Cost
- Lower Air-Conditioning Requirements
- Reduced Total Cost of Operation & Ownership
- High Efficiency Provides Rapid Return of Investment

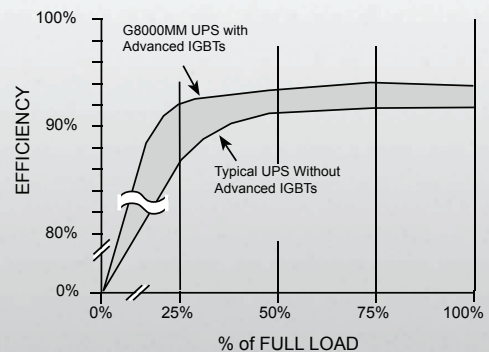

## Hybrid Static Transfer Switch

- Each UPS Module Equipped with Hybrid Static-Transfer Bypass Switch
- Make-Before-Break Switch Design Ensures a Seamless Transfer of Power to Critical Load
- Hybrid SCR/Contactor Design Improves Static-Switch Efficiency to Nearly 100%
- Lowers Utility Cost & Overall Cost of Operation

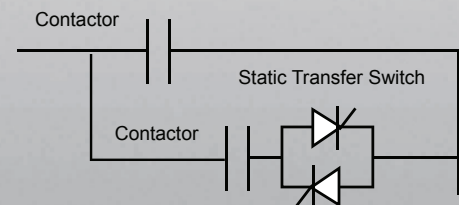

# G8000MM System Configurations

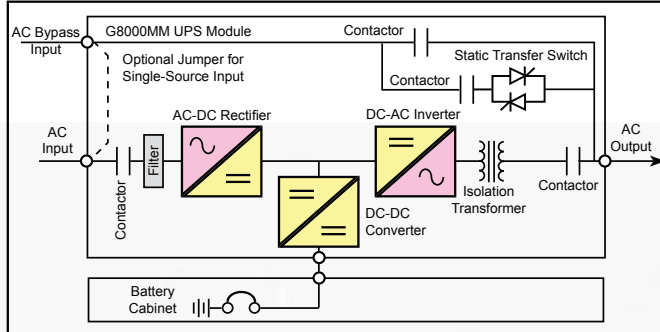

## Single Module

- Built-In Hybrid Internal Static Bypass Circuit
- Output Isolation
- DC-to-DC Isolation
- Single or Dual-Source Input
- Monitor UPS Locally or Remotely
- Controllable via Local LCD Panel or Customer-Supplied Interface

## Parallel Multi-Module

- Parallel up to Eight Units
- Load Capacity from 100 to 4000 KVA
- Control Circuitry Built Into Each UPS for Redundancy
- Distributed Bypass Eliminates Single Point of Bypass Failure
- Redundant Switches Reduce Single Point of Failure in One Static Switch Cabinet Design
- Controlled through Each Local UPS LCD Panel or through Customer-Supplied Interface
- Monitor Status through UPS, Tie Cabinet, or Across Local Area Network
- Line Reactors in Tie Cabinet Ensure Balanced Load Distribution in Bypass Mode
- Tie Cabinet Requires No Sophisticated Control Circuitry for Ease of Future Expansion

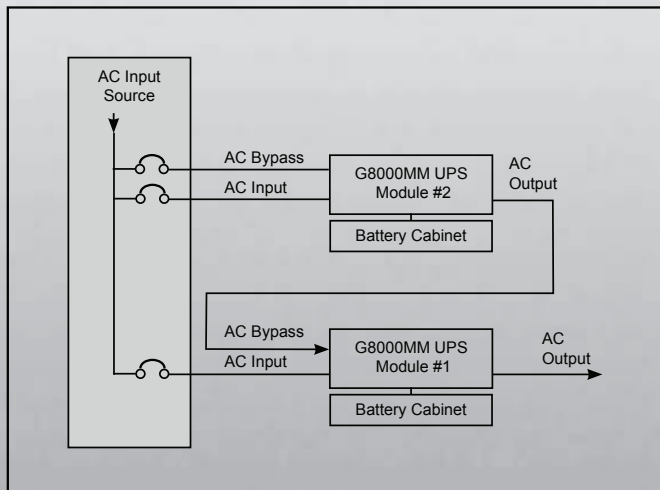
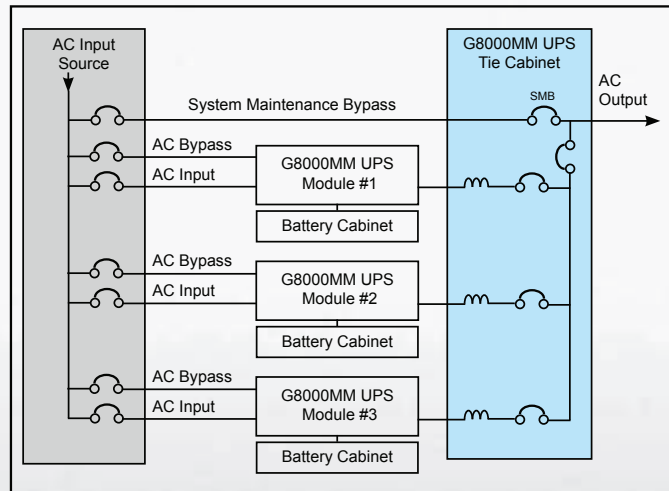

## Isolated Redundant

- Backup for any UPS with Dual-Input
- Requires No Parallel Tie Cabinet for Smaller Footprint & Lower Purchase Cost
- Feature can be Added Later to Accommodate Expansion or Budget Limitations
- Simple, Reliable Design Significantly Increases Reliability

# G8000MM Options

## Remote Monitoring

RemotEye II® offers remote real-time monitoring and analysis of UPS operation via HTTP and SNMP.

- Multiple Monitoring Options: Locally at UPS, at Tie Cabinet, Remotely via Local Area Network, or Annunciator
- Each UPS Module's Data Port may be Tied to Optional Network Monitor
- Optional Industrial Bus ProtoNode Module Supports:
  - SNMP
  - Modbus
  - AB Ethernet IP
  - Metasys N2
  - TCP/IP
  - RTU
  - BACnet
  - MSTP

An optional hard-wired remote status alarm panel (RSAP) enables remote-monitoring of UPS alarm/status points up to 1000 feet away.

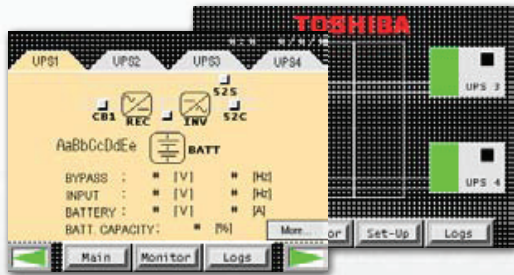
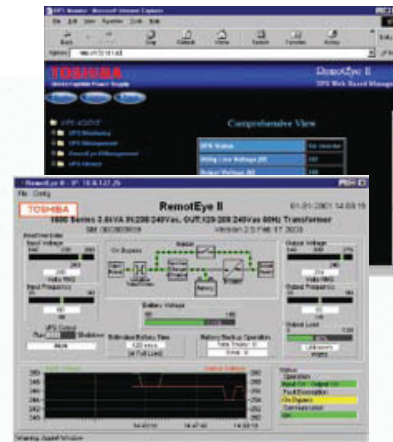

## Tie Cabinet System Monitor

In multi-module systems, the G8000MM UPS tie cabinet has a five-inch color LCD display for monitoring unit and system status.



## Battery Cabinets & Battery Racks

- Matching Battery Cabinets Provide Uniform Appearance, Ease of Installation, & Simple Connection
- Battery Cabinets Available Using Valve-Regulated Lead Acid (VRLA)
- Battery System Available Using Flooded Batteries
- DC Breaker Disconnects Standard

## Power Distribution Unit/Remote Power Panel Options

- PDUs Available in Wide Variety of Voltage Options to Meet Specific Load Requirements
- PDUs Offered in Diverse Selection of Distribution Options
- PDU and RPP Options Offered in Compact Package to Maximize Floor Space
- RPPs Allow Ease of Installation for Server Power Distribution
- RPPs Available with Monitoring Capabilities

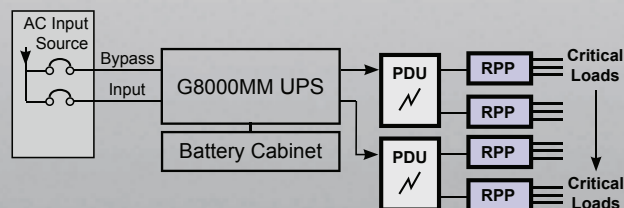



# G8000MM Specifications

Model Number		T8MS3K-10KK6XSN	T8MS3K-15KK6XSN	T8MS3K-22KK6XSN	T8MS3K-30KK6XSN	T8MS3K-37KK6XSN	T8MS3K-50KK6XSN	T8MS3K-62KK6XSN	T8MS3K-75KK6XSN	
Capacity	KVA/KW	100/80	150/120	225/180	300/270	375/338	500/450	625/562	750/675	
Topology	True On-Line, Double-Conversion, IGBT PWM									
Input	Voltage	AC Input: 480 V, Three-Phase, Three-Wire + Ground; Bypass Input: 480 V, Three-Phase, Four-Wire + Ground								
	Voltage Range	480 V, +15% to -15% (408 to 552 V Without Utilizing Battery)								
	Power Factor	> 0.98								
	Current THD	< 6% at 100% Load; 9% Maximum at 50% Load								
	Frequency	60 Hz, ± 5%								
	Walk-In	5 to 30 Seconds (Adjustable)								
Output	Voltage	480/277 V, Three-Phase, Four-Wire + Ground								
	Frequency	60 Hz, ±0.05% in Free-Running Mode								
	Voltage Regulation	±1%								
	Power Factor	0.8 Nominal				0.9 Nominal				
	Voltage THD	2% Maximum THD at 100% Linear Load 5% Maximum THD at 100% Non-Linear load								
	Transient Response	±2% Maximum THD at 100% Step Load ±1% Maximum at Loss/Return of AC Power ±5% Maximum at Load Transfer to/from Static Bypass								
	Transient Recovery	≤ 16.7 ms								
	Voltage Unbalance	1% Maximum at 100% Unbalanced Load								
	Phase Displacement	1° Maximum at 100% Load								
	Overload (Inverter)	125% for 10 Minutes; 150% for 1 Minute								
	Overload (System)	1000% for One Cycle (Available with Bypass)				Maximum 500% for One Cycle (Available with Bypass)				
	Battery	Type	Lead Acid (VRLA or Flooded)							
Nominal Voltage		480 VDC								
Minimum voltage		400 VDC								
Charge Current (ADC)		13	19.5	29.3	39	48.7	65	92.5	92.5	
Number of Cells		240								
Environment	Cooling	Forced Air								
	Temperature Range	32° to 104°F (0° to 40°C) During Operating and Storage								
	Relative Humidity	5% to 95% Non-Condensing								
	Heat Rejection (BTU/h)	18,353	28,465	44,105	60,894	76,117	96,271	120,339	144,407	
	Efficiency	93.7%	93.5%	93.3%	93.8%	93.8%	94.1%	94.1%	94.1%	
	Altitude	0 to 9000 ft.								
	Audible Noise @ 1m	68 DBA	72 DBA	76 DBA	78 DBA	78 DBA	80 DBA			
Dimensions	Width	43.3 in.	47.2 in.	55.1 in.	76.8 in.		114.2 in.	129.9 in.		
	Depth	29.8 in.			37.7 in.			49.5 in.		
	Height	79.7 in.								
	Weight	2061 lbs.	2579 lbs.	3263 lbs.	4564 lbs.	4916 lbs.	6923 lbs.	9193 lbs.		
Features	Dual-Input Feed, Output Isolation Transformer, RS232 and Dry Contact Interface, Single or Parallel Operation									
Standards	UPS: UL1778, CUL, NEMA PE1, ISO9001, ANSI C62.41 (IEEE 587)									
Warranty	Three-Year Warranty on UPS Electronics Standard, Up to Five Years Available; Three-Year Warranty on Batteries with Startup Purchase; See Toshiba Warranty Policy for Full Details									
Service	24-Hour, 365-Day Technical Support 1-877-867-8773									